

ctx

carbotechnix

CARBON BLADES VICTUM

MODEL 2013



**CREATED
TO WIN !**



SPECIFICATION



Tube: Carbon

Runner: 1,1 Bimetal
up to 64 Hrc

Bridge: anodized
aluminium alloy
7075T6

Sizes: 36-44

 Thanks to the use of carbon fiber tube has a lower weight of approx. 35%.

 Specific property of carbon provide ice skates optimum elasticity and muting vibrations.

 Profile tubes has been adapted to the specific characteristics of the carbon, so that it is sufficiently rigid and permanently connected to the runner.

 Appropriately shaped bridge to get better parameters and reduce resistance while skating.

 A large range of shoes settings.

 Springs hidden inside bridge.

The shape of the bridge was designed and optimized for high strength and stiffness of the whole layout skates with relatively small mass.

Stress test
of finite-element
method
(FEM)

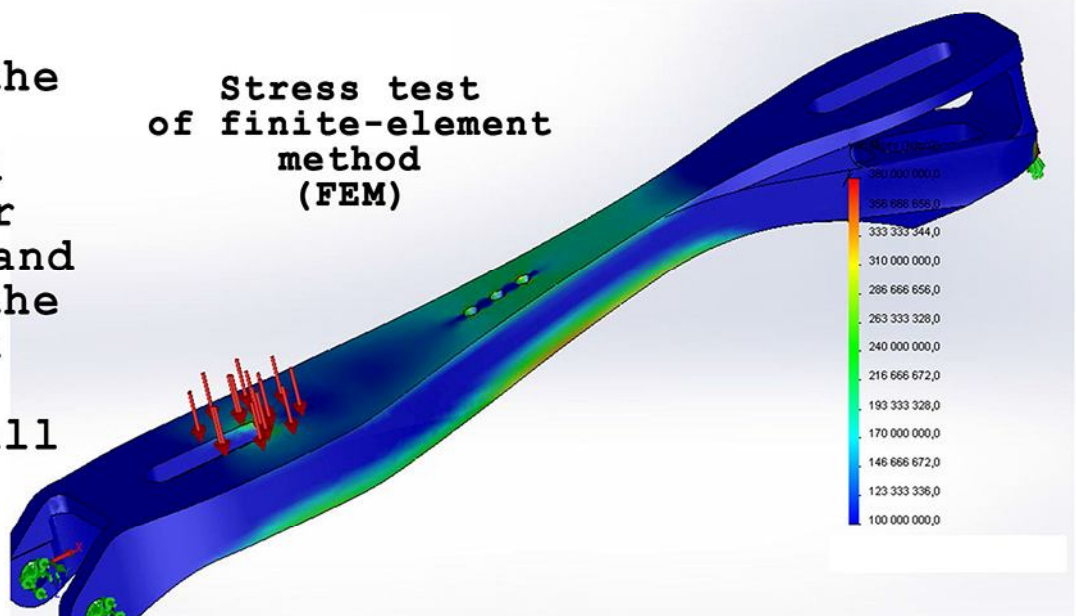

SIZE TABLE

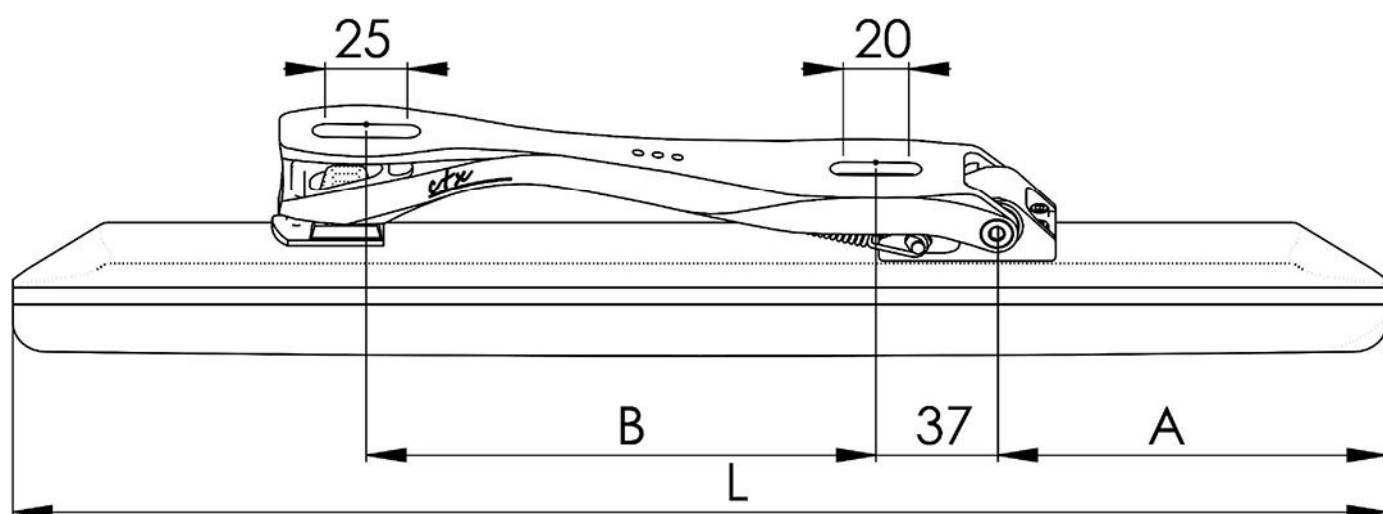

| SIZE | L | A (mm) | B (mm) | WEIGHT (gram/pair) |
|------------|----------|--------|--------|--------------------|
| 16" / 36 | 16/406 | 118 | 145,5 | 720 |
| 16,5" / 38 | 16,5/419 | 121 | 155,5 | 740 |
| 17" / 40 | 17/432 | 124 | 165,5 | 760 |
| 17,5" / 42 | 17,5/445 | 127 | 175,5 | 780 |
| 18" / 44 | 18/457 | 130 | 185,5 | 800 |

Are you special?

**We will make a unique set of
matched to your needs!**



Visit our website
and see for
yourself what
products has in its
offer, the company
CARBOTECHNIX!!

We will inform You about news
and promotions,
which soon will
appear in our offer.



We are open to all
your suggestions.
If you have any
questions or concerns
we will be happy to answer them.

CARBOTECHNIX

www.carbotechnix.com.pl
ctx@carbotechnix.com.pl